

STARBOX - CONDENSER UNITS

INSTALLATION, OPERATION AND MAINTENANCE INSTRUCTIONS

Table of Contents

1. General Information.....	1
2. Handling and Storage	1
3. Installation	1
4. Electrical Connections	4
5. Start Up	5
6. Operating	5
7. Maintenance and Service	5
8. Sound Pressure Level.....	6
9. Invalidity of Warranty	7

Contact:
Address : Organize Deri Sanayi Bölgesi
18. Yol 34957 Tuzla İSTANBUL, TURKEY
Telephone : (0216) 394 12 82
Fax : (0216) 394 12 87
E-mail : info@friterm.com
Web : www.friterm.com

1. GENERAL

This document specifies the instructions for installation, operation and maintenance of **Condenser Units (KU Models of STARBOX)** produced by FRITERM A.Ş., Turkey.

The instructions below should be observed for health and safety reasons, during installation, usage and maintenance of the product.

Upon receipt, the units should be visually inspected and supplier should be notified within 7 days incase of any damage or missing.

2. HANDLING AND STORAGE

Check carefully if there is any damage on package or product.

Store the product in its original packing in a dry area protected from the improper weather conditions or protect it from dirt and environmental effects until final installation.

Do not keep the product in extreme hot and cold places.

Avoid extremely long storing time (maximum one year is recommended for storing).

If a fan is stopped for long periods in humid atmosphere, it should be run for minimum of two hours per month to remove any damp that may have condensed within the motor.

A forklift or crane should be used to carry heavy products. Work gloves should be used if light products are handled without any lifting vehicle.

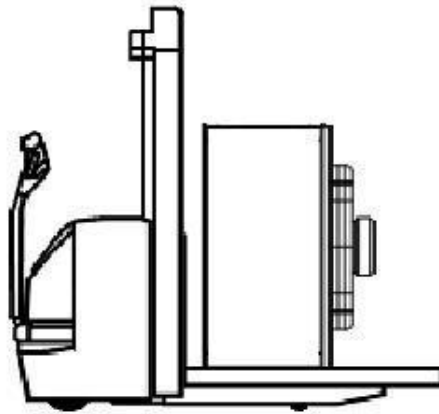

Fig.1. Handling scheme during carriage

3. INSTALLATION

System installer is responsible for the accordance of adequate installation and safety informations with valid standards and instructions. (DIN EN 292/294)

Builder or operator should observe EMC 89/336 EEC instructions.

Before installation, it should be ensured that product's technical specifications are in accordance with desired working conditions.

3.1. Location

Product is designed to work only for fixed location. It must be installed to stable base.

In order to get optimum performance, ventilation of working place should be sufficient and there should not be any hazardous substances and explosives nearby.

Air motion should not be adversely affected by obstructions and the inlet air should not be undesirably heated or cooled by other devices.

3.2. Floor Mounting

If the unit is mounted on the floor, a minimum distance of 25 cm must be left between the suction of the unit and the wall.

If the unit is mounted on the roof, isolation of the feet of the unit and the roof is recommended.

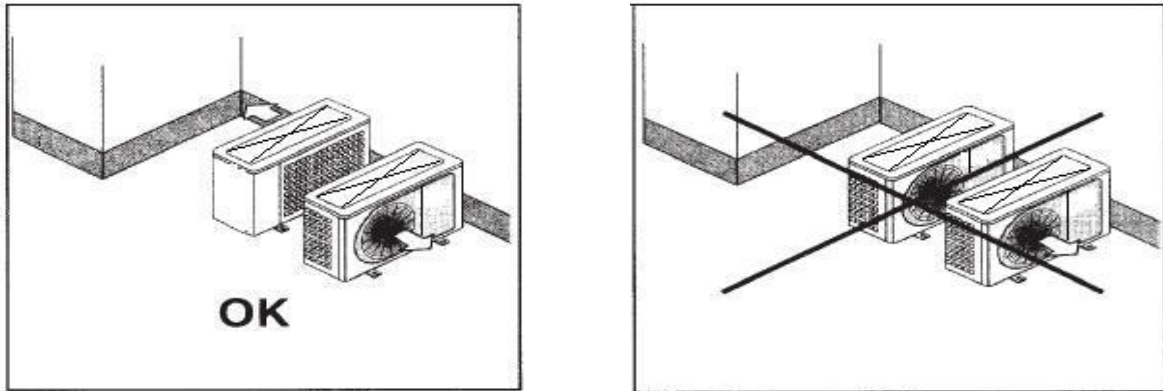

Fig. 2. Unit Placement

3.3. Installation

WARNING! INSTALLATION AND ELECTRICAL CONNECTIONS MUST ONLY BE CARRIED OUT BY QUALIFIED PERSONNEL.

WARNING! BE SURE THAT PRODUCT IS NOT CONNECTED TO THE POWER SUPPLY DURING INSTALLATION.

It should be careful for any damage on connection pipes and tubes outside, during products unpackaging and installing to its place.

The installation position of product should be in accordance with its design.

Connections used in installation should be adequate to support the total operational forces.

Installation should not carry external vibrations to the product. If necessary, a vibration eliminator should be added to the system.

3.3.1. System accessories installation

The system accessories composed of receiver, liquid line solenoid and ball valves, liquid sight glass, liquid line filter drier and dual pressure control and manometers.

KU units are delivered without compressors and recommended compressor models are available in product brochure.

Receiver

- A liquid receiver serves to accumulate the reserve liquid refrigerant, to provide a storage for off-peak operation, and to permit pumping down of the system. The receiver also serves as a seal against the entrance of gaseous refrigerant into the liquid line.

Liquid Line Solenoid valve

- Solenoid valve will allow all of the refrigerant to be pumped out of the low side when the thermostat has been satisfied. This reduces the risk of refrigerant migrating or flooding back to the compressor.
- In case of replacement, it is advisable to make sure that the refrigerating system is clean before connecting the valve to the pipe.
- Check that the flow direction in the pipe corresponds to the arrow stamped on the body of the valve.
- The valve can be mounted in whatever position except with the coil of the valve pointing downwards.
- The brazing of valves with solder connections should be carried out with care, using a low melting point filler material such as silver alloy.

- It is not necessary to disassemble the valves before brazing but it's important to avoid direct contact between the torch flame and the valve body, which could be damaged and compromise the proper functioning of the valve.
- Before connecting a valve to the electrical system, be sure that the line voltage and frequency correspond to the values marked on the coil.

Ball Valve

- Ball valves will allow keeping the system refrigerant in the coil and receiver during system accessories maintaining.
- Moreover the access fitting will assure to charge refrigerant in the system safely.
- In case of replacement, it is advisable to make sure that the refrigerating system is clean before connecting the valve to the pipe.
- Check that the flow direction in the pipe corresponds to the arrow stamped on the body of the valve.
- The brazing of valves with solder connections should be carried out with care, using a low melting point filler material.
- It is not necessary to disassemble the valves before brazing but it's important to avoid direct contact between the torch flame and the valve body.

Sight Glass

- Liquid indicators and moisture liquid indicators ensure a fast and safe inspection of the conditions of the refrigerant fluid in the circuit concerning regular flow.
- Liquid indicators also ensure inspection of the regular return of oil to the compressor crankcase.
- The moisture content shown the "green" color, can be considered admissible for the proper working of the system.
- When the sensitive element from green fade to "yellow", working conditions of the system could become difficult.
- When the sensitive element becomes "yellow", it's time to substitute the dehydrator filter.
- If the charge and working condition are normal, the refrigerant fluid appears perfectly liquid underneath the "lens" of the indicator.
- The presence of bubbles indicates that the refrigerant fluid is partial evaporating along the liquid line and no subcooling or insufficient refrigerant in the whole system.
- At the start-up the color of the sensitive element may be yellow, due to exposure to air humidity and to moisture in the circuit.
- When the moisture of the refrigerant is brought back to acceptable levels with the dehydrator, the indicator color is once again green.
- In case of persisting yellow, measures have to be taken to eliminate moisture.
- Avoid direct contact between the torch flame and the indicator body or ring, which could be damaged and compromise the proper functioning of the indicator.

Dryer

- Filter dryer is used to remove foreign materials and moisture that may be entered to the system during installation.
- The element is allowed to put in any position inside the refrigerating system. However it is always advisable to install a moisture indicator downstream the filter, which will show the refrigerant moisture and, consequently, the degree of efficiency of the filter.
- Avoid direct contact between the torch flame and the body of the dryer during brazing.

Dual Pressure Control

- The dual pressure control should be mounted on a flat surface to prevent distortion of the control case. Ensure sufficient room to connect capillaries and adjust controls.

- It should be mounted in an environment appropriate with the control enclosure.
- Wiring should be routed to prevent the possibility of water running along cables into the control.
- Wiring should conform to any applicable approvals, codes and industry practice. Electrical ratings must not be exceeded.
- Capillaries should be secured to prevent excessive vibration, and must not be twisted or kinked. Any bends must have a minimum radius of 25 mm.
- The bellows must be held with a spanner while tightening flare-nut(s).

Manometers

- Capillaries should be secured to prevent excessive vibration, and must not be twisted or kinked. Any bends must have a minimum radius of 25 mm.
- The bellows must be held with a spanner while tightening flare-nut(s).

Piping installation

- Piping from and to the unit should be selected according to design capacity and not to the unit inlet-outlet pipe sizes.
- The piping should be done independently of the unit in such a way that any of the outside vibration will not effect to the unit.
- The piping should be done by the qualified personnel only.
- The brazing of suction-discharge connections of compressors with solder connections should be carried out with care, using a low melting point filler material.
- Avoid direct contact between the torch flame and the body of the compressor during brazing.
- All pipes brazing should be done carefully in order not to have any gas leakage.
- Especially the brazing of the capillary pipes connections are done not to be blocked of the holes with very care.

4. ELECTRICAL CONNECTIONS

WARNING! ELECTRICAL CONNECTIONS MUST ONLY BE CARRIED OUT BY QUALIFIED PERSONNEL.

The electric connections should be done as shown below for single and double fans units.

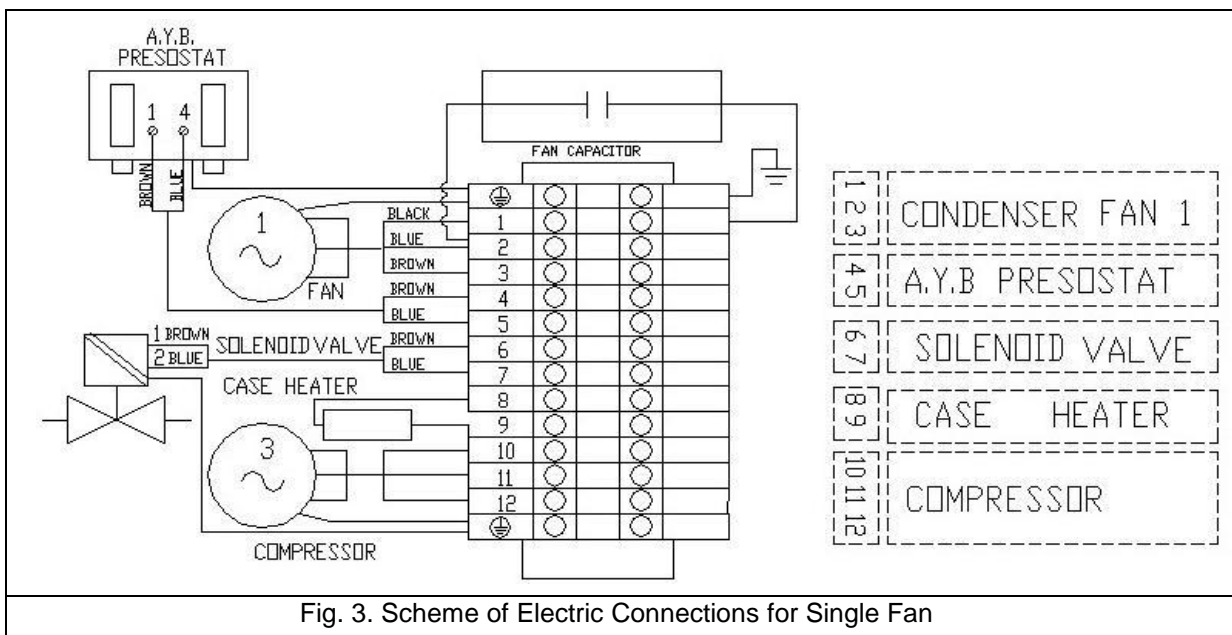

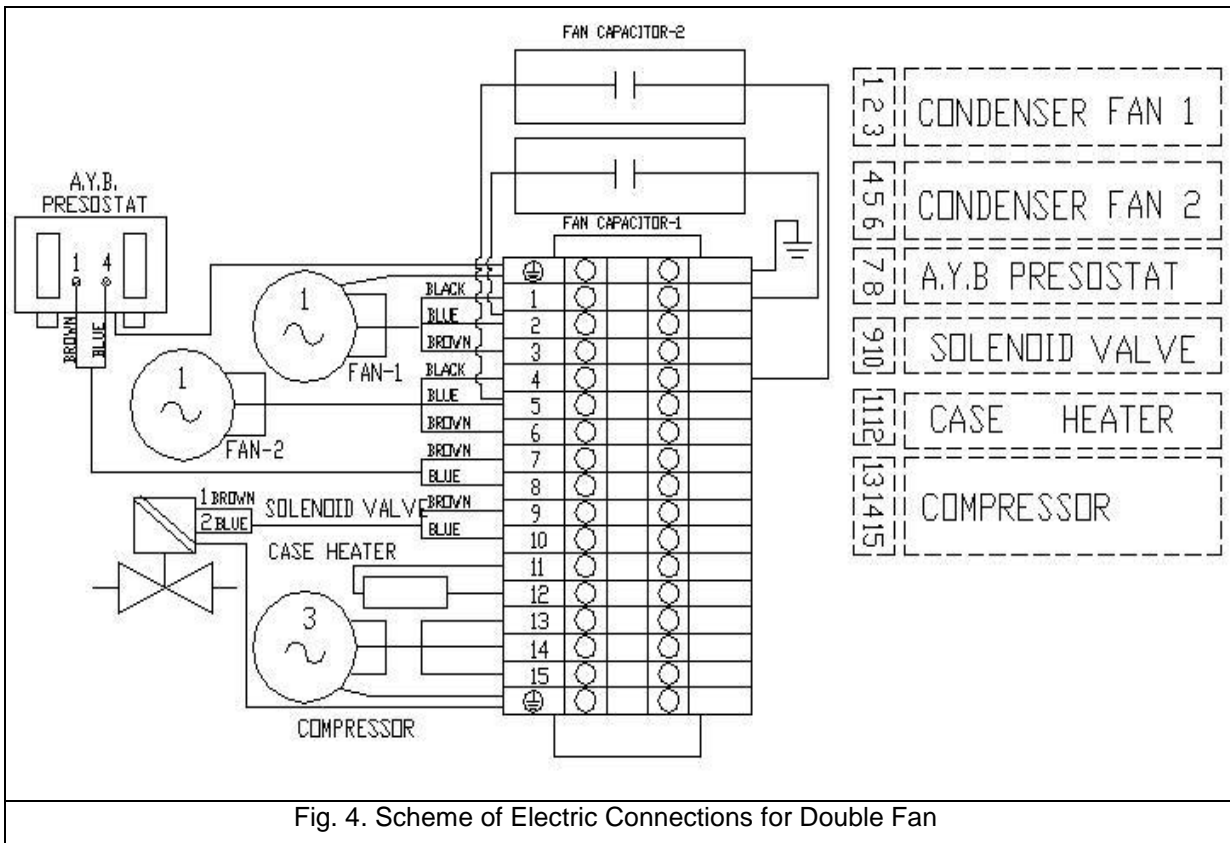

Fig. 4. Scheme of Electric Connections for Double Fan

5. START UP

- Before start up, be sure that all the protective grates of the fans and coils are fixed, connections of compressor motor and system elements are safe, mechanical and electrical connections are correct, cables are far away from the fans, fans can rotate freely without obstacle and the maximum allowable pressure adjusting to the pressure control is done.
- The voltage, working fluid and the maximum working pressure stated for the unit is proper to the working surrounding.
- The supporting to the unit is sufficient enough to carry the overall weight of the unit.

6. OPERATING

If a fan is stationary for long periods in humid atmosphere, it should be run for minimum of two hours per month to remove any damp that may have condensed within the motor.

It is recommended for fans to start up to 6 times, in extreme cases maximum 10 times per hour.

When fans are running, objects that may pass through the fan guards such as a piece of cloth or long hair, should be kept away from fan.

Stay away from the airways of the fans when fans are running.

The operation should be stopped and the supplier should be consulted in case of any unusual working condition, like an unusual operating noise, is realized.

Before touching, it is recommended to ensure that the headers and the connection pipes are neither too hot nor cold due to working conditions of the fluid side.

Intensive vibrations, due to uneven running of fans, may lead to outage.

Do not maintain and service the product during operation.

7. MAINTENANCE AND SERVICE

WARNING! ALL THE ELECTRIC MUST BE DISCONNECTED BEFORE MAINTENANCE AND SERVICE IS UNDERTAKEN.

Maintenance and service must only be carried out by qualified personnel.

Please follow safety regulations and employee's protection rules during maintenance and service. (DIN EN 50110)

Fluid circulation should be stopped and it must be ensured that there is no power supply connection during maintenance and service. Wait until system's temperature reaches the ambient temperature if possible.

If pipes in the product or connection pipes, need to be repaired, the fluid in system must be discharged.

Under normal operating conditions, fans do not require 'bearing maintenance approximately for 30.000-40.000 hours.

Lubrication is unnecessary unless this time is exceeded or bearings are damaged.

Bearings should be replaced with original parts. During the maintenance and service of the fans, instructions prepared by fan the supplier should be followed. If necessary, apply to the manufacturer.

Be sure that there is not any left tool or unfamiliar object in or near the product during maintenance and service.

After maintenance and service, before running the system, control the Initial Starting instructions.

7.1. Periodic Controls (every 3 - 6 months)

- The surface of the heat exchangers should be inspected for dirt and dust and if necessary it should be cleaned with soft brush, pressurized air or pressurized hot water or similar method to ensure the correct operation of the unit.
- If the condenser coil is obstructed by dirt, the condensing temperature will be higher than normal and hence the higher running costs, less compressor efficiency and overheating of the compressors and fans will be appeared.
- Mechanical and electrical connections of the fans should be controlled. Fans should rotate freely. Fan guard should be stable.

7.2. Periodic Controls (Once a year)

- All connections, especially fan and motor mounting must be ensured to be secure.
- Pipeline should be controlled for damage or leakage. There can be leakage if pipes are worn out.

7.3. When necessary

Please take caution not to damage fins and fans. The chemicals that can be in reaction with the product's material should not be used. Electrical connections and fan motors should not be wetted during cleaning.

8. SOUND PRESSURE LEVEL

FAN DIAMETER	RPM	Sound Pressure Level (dBA)	
		Number of Fans	
		1	2
Ø 400	1430	44	47
Ø 450	1400	47	50

Sound pressure levels as dBA at a distance of 10 m for different number of standard fans used in FRITERM products (REF: EN13487). Test data are taken from fan manufacturer's documents. The values given above are only for comparison. Actual values may depend on structure of the environment and installation characteristics.

9. INVALIDITY OF WARRANTY

The warranty declared in sales contract, is valid unless installation; operation; maintenance instructions, given in this document and its attachment, are violated.



Adres : Organize Deri Sanayi Bölgesi
18. Yol 34957 Tuzla İSTANBUL, TURKEY
Telefon : (0216) 394 12 82
Faks : (0216) 394 12 87
E-posta : info@friterm.com
Web : www.friterm.com